

Intuitive Weighing Fast. Reliable. Easy-to-Use.



Intuitive functionality with an excellent return on investment: METTLER TOLEDO's FreshBase scale is designed for grocery retailers who need reliable and robust solutions with a low total cost of ownership.

FreshBase offers easy-to-use functionality that keeps your fresh food weighing applications running efficiently. Its robust housing and innovative design can withstand the rigors of daily use, while its user interface requires less time spent on training. Increase the productivity of your fresh departments with FreshBase.

METTLER TOLEDO

FreshBase

Innovation through simplicity

Less time training employees on how to use weighing equipment means more time spent serving customers. FreshBase scales support efficiency and productivity with intuitive usability. Convenient touchscreen operation guides operators through the entire weighing process step-by-step.

Grocery retailers can be assured of dependable performance from their FreshBase scales. The robust design and high-quality components offer maximum operational uptime and an extended life cycle under heavy daily use.



Enhanced Productivity

FreshBase offers operators an intuitive user interface that reduces training times, enhances staff productivity, and eases workflows. Focus more attention on customers with simplified weighing processes enabled by the fully-featured efficiency of FreshBase.



Maximum Durability

Designed to withstand daily usage in busy departments, FreshBase's robust design with aluminum die-cast housing and groove-free exterior was built with a focus on ergonomics, hygiene and durability. Highly resistant to the rigors of heavy operator use, FreshBase supports operations through maximized uptime.



Innovative Software

FreshBase delivers enhanced integration by supporting communication with existing corporate applications through browser-based and web services technologies. FreshPro software provides ease of maintenance by enabling increased self-diagnostics accessible for in-store or remote servicing.

Intuitive User Interface

- User-friendly for both new employees and experienced operators
- Less time required to train operators means more time for customers
- Simplified operation through a familiar GUI that reduces navigational clicks and leverages smartphone-like gestures

Large Customer Display

- Adjustable 7" widescreen customer display enhances visibility of weight and price information
- Enables in-store marketing of digital content and cross promotions directly in the customer's line of sight



Best-in-class Operator Display

- Adjustable, anti-glare 12.1" widescreen touchscreen operator display
- Engineered for maximum efficiency and intuitive usability

Outstanding Serviceability

- Equipment servicing is simplified with accessibility to internal components from top of device
- Remote software service capability supports service and maintenance

Rapid Label Change

- Improved productivity with fast and easy label roll changes
- Design upgrade enables durable performance and fast, quality printing

Find more information at:

► www.mt.com/retail-FreshBase



FreshBase – Powered by FreshPro Software

- Simple integration into existing processes and applications
- Dynamic screen layout with advanced GUI
- Enhanced graphics and content management
- New workflows supported (multi-ticket items, incoming orders)

FreshBase C3 – Technical data

METTLER TOLEDO's FreshBase scale is designed for grocery retailers who need reliable and robust solutions with a low total cost of ownership.



Operator Touchscreen Display

- 12.1-inch (26.1 cm) widescreen capacitive touchscreen in luminous and high-contrast LED-backlit technology
- Screen resolution: 1280 × 800 pixels
- Continuous tilt angle adjustments (stepless)

Customer Display (optional)

- 7-inch (15.4 cm) widescreen customer display with luminous and high-contrast LED-backlit technology
- Screen resolution: 800 × 480 pixels
- Base or tower mounting options available
 - 12" Tower Upgrading Kits FB: #30571160
 - 24" Tower Upgrading Kits FB: #30584061

Printer

- 3-inch label printer
 - Printing speed: up to 125 mm/s
 - Print resolution: 8 dots/mm
- Optional external printer
 - Stand Alone Kit Printer FLLP3 & FLP3: #30676301
 - Printer options: 3-inch label printer: #30565505; 3-inch linerless printer: #30494889
 - Cable options: 1.4m: #30260345; 2m: #30212467; 4m: #30431528 (External printer and cable must be ordered separately)

Accessories

- Seafood pan: 64064884
- Lobster pan: 64064885

Processor

- Intel® Celeron® N3350 Dual Core 2.4 GHz Burst Frequency*

Data Storage

- 4 GB RAM
- 8 GB Flash memory

Interfaces and Protocols

- Ethernet interface (10/100)
- 2 × USB 2.0 ports
- 1 × USB 3.0 port
- Integrated wireless solution for wireless data transmission in accordance with standard IEEE 802.11 ac/a/b/g/n (2T2R), compliant with MU-MIMO

Operating System

- MT Linux Embedded OS

Power Supply

- 100 – 240 V AC, 50 / 60 Hz

Average Power Consumption

- During operation: ca. 18W

Housing

- High stability due to aluminum die-cast casing
- Shock-resistant ABS polymer display casing
- Casing has an anti-stick coating
- Seamless cover resistant to spills
- Color: Black

Options

- Available as Controller without load cell for Prepack applications
- For use with Step-Saver handwrap station

*Celeron is a trademark of Intel Corporation or its subsidiaries in the U.S. and/or other countries.

All dimensions in inches

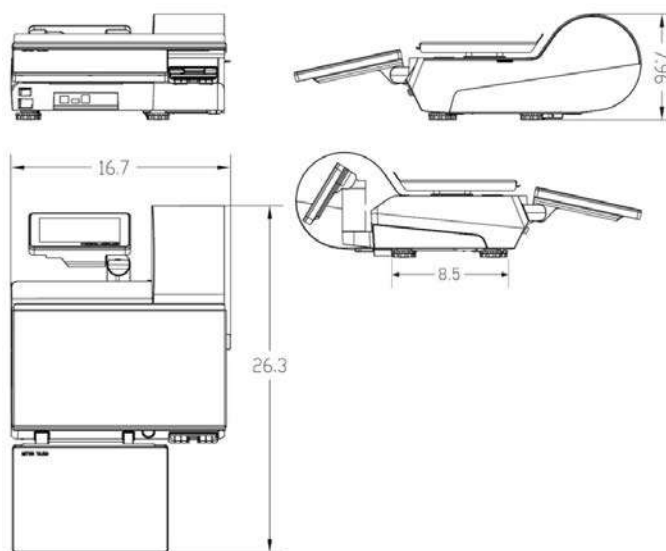

FreshBase – Green MT Certified

- Robust design for long equipment life cycle
- Reduced power consumption for energy savings

METTLER TOLEDO Group

Retail Division
Local contact: www.mt.com/contacts

Subject to technical modifications
© 05/2022 METTLER TOLEDO. All rights reserved
Document No. 30458490 A
MarCom Industrial

www.mt.com/retail

For more information

