



MODEL IDS623 Series SDS Load cell

SDS LOAD CELL
HIGH PRECISION
& PERFORMANCE

Features

- Stainless steel construction
- S-type load cell
- For used tension or compression



Specification

PARAMETER	VALUE	UNIT
Capacity	50 , 100, 150, 200 ,300 ,500 , 750 ,1000	kg
Rated output	2 ± 0.01	mV/V
Zero balance	± 0.05	mV/V
Input resistance	385 ± 10	Ohms
Output resistance	350 ± 2	Ohms
Non linearity	± 0.025	% R.O.
Hysteresis	± 0.025	% R.O.
Non-repeatability	0.02	% R.O.
Creep	± 2	$\mu\text{V} / 12\text{V} / 80\% \text{ R.O.} / 1\text{min}$
Zero shift	± 2	$\mu\text{V} / 12\text{V} / 80\% \text{ R.O.} / 1\text{min}$
Power on stability	± 2	$\mu\text{V} / 12\text{V} / 2 \text{ min}$
Temperature effect on zero	± 0.05	% R.O / 10 °C
Temperature effect on rated output	± 0.02	% R.O / 10 °C
Operating temperature range	-10~+40	°C
Excitation recommended	5 ~ 15	V
Safe overload	150	% R.O.
Insulation resistance	$\geq 5000 (50 \text{ VDC})$	Mega-Ohms
Cable , Length	$\varnothing 5 \text{ mm} \times 2.5 \text{ m}$	

All specifications listed are subject to change without notice.

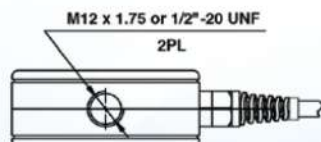
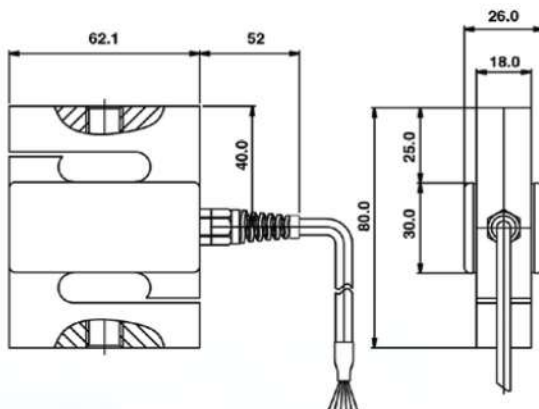

Color code of cable

