



## Incubator IF750

The incubator I is at home everywhere in the world of research, medicine, pharmaceuticals and food analytics, as well as food chemistry.



With the help of our model selection, with dimensioned model sketches and extensive technical data for download, you can find the right incubator for your needs. The flexibility and technical features of our appliances meet all possible needs. Put us to the test!

From 32 models, expandable with convenient, approved and tested accessories, you will easily find the incubator ideally suited to your needs. According to your individual application the two model variants SingleDISPLAY cover all requirements of thermal safety, precision and quality assurance.

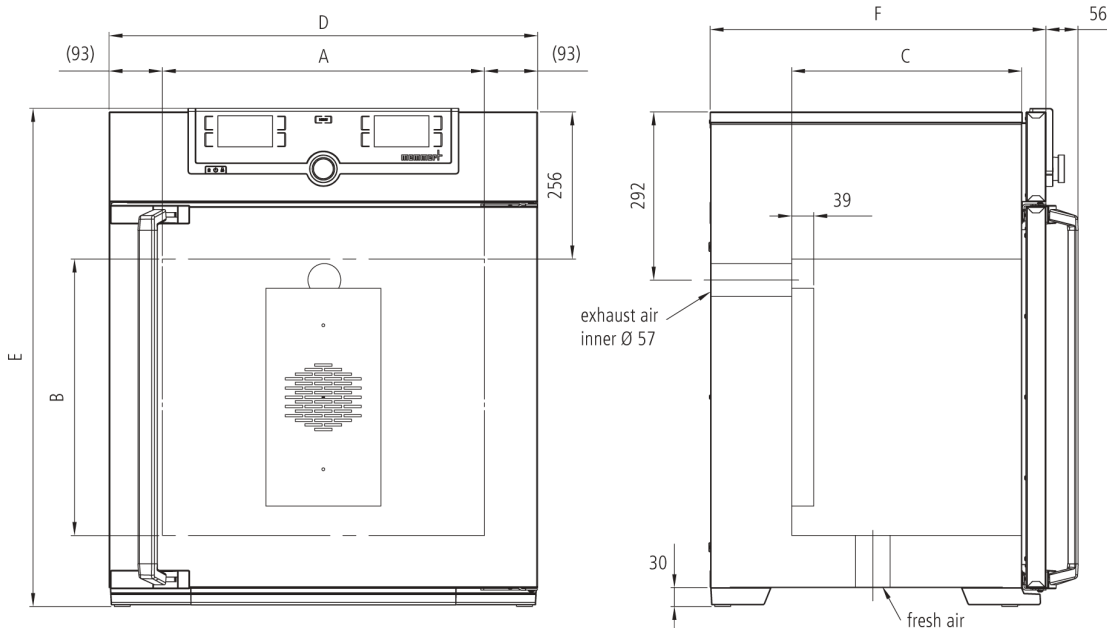

## Control of standard components

<b>Control</b> <b>COCKPIT</b>	adaptive multifunctional digital PID-microprocessor controller with high-definition TFT-colour display
<b>Temperature</b>	1 Pt100 sensor DIN class A in 4-wire-circuit
<b>Timer</b>	Digital backwards counter with target time setting, adjustable from 1 minute to 99 days

## Temperature

min. 10°C above ambient up to +80°C

<b>resolution of display for setpoint and actual temperature values</b>	0.1°C
---	-------

## Control technology

**adjustable parameters** temperature (Celsius or Fahrenheit), fan speed, air flap position, programme time, time zones, summertime/wintertime

**Function Setpoint****WAIT** the process time does not start until the set temperature is reached

**Language setting** German/English/Spanish/French

**Calibration** three freely selectable temperature values

## Ventilation

**Fan** forced air circulation by 2 quiet air turbines, adjustable in 10 % steps

**Fresh air admixture** adjustment of pre-heated fresh air admixture by air flap control in 10 % steps

**Vent** vent connection with restrictor flap

## Communication

**Programming** AtmoCONTROL software for reading out, managing and organising the data logger via Ethernet interface (temporary trial version can be downloaded). USB stick with AtmoCONTROL software available as accessory (on demand).

**Documentation** programme stored in case of power failure

## Safety

**Temperature control** adjustable electronic overtemperature monitor and mechanical temperature limiter TB, protection class 1 according to DIN 12880 to switch off the heating approx. 20°C above nominal temperature

**Autodiagnostic system** for fault analysis

## Standard equipment

<b>Door</b>	fully insulated stainless steel doors with 2-point locking (compression door lock)
<b>Door</b>	inner glass doors
<b>Installation</b>	on lockable castors
<b>Internals</b>	2 stainless steel grids
<b>Scope of delivery</b>	incl. works calibration certificate for +37°C
<b>Housing</b>	rear zinc-plated steel
<b>Interior</b>	easy-to-clean interior, made of stainless steel, reinforced by deep drawn ribbing with integrated and protected large-area heating on four sides

## Stainless steel interior

	$w_{(A)} \times h_{(B)} \times d_{(C)}$ : 1040 x 1200 x 600 mm
	Volume 749 l
	Max. loading of chamber: 300 kg

## Textured stainless steel casing

	$w_{(D)} \times h_{(E)} \times d_{(F)}$ : 1224 x 1726 x 784 mm
--	--

## Electrical data

	230 V, 50/60 Hz / approx. 2000 W
	115 V, 50/60 Hz / approx. 1800 W

## Packing/shipping data

the appliances must be transported upright

<b>Customs tariff number</b>	8419 8998
<b>Country of origin</b>	Federal Republic of Germany
<b>WEEE-Reg.-No.</b>	DE 66812464
	Dimensions approx incl. carton B x H x T: 1330 x 1910 x 1050 mm
	Net weight approx. 217 kg
	Gross weight carton approx. 288 kg